

# Discovering Buddhism

## Module 9

### Samsara and Nirvana

#### Overview and Summaries

#### **Content**

DAY 14 – The General Sufferings of Samsara (overview and detail)  
DAY 14 – The Sufferings of the Higher Rebirths (overview and detail)  
DAY 15 – Understanding the Causes of Samsara Realms (overview and detail)

#### **Sources**

##### Main Source:

Liberation in the Palm of Your Hand, Pabonka Rinpoche, Wisdom Publications, page 473-543.

##### Supporting Sources:

Path to Enlightenment in Tibetan Buddhism, Geshe Acharya Thubten Loden, Tushita Publications, page 389-437, 459-476.

Wish-fulfilling Golden Sun, Lama Zopa Rinpoche, page 84-105.

DAY 14

The General Sufferings of Samsara  
and  
The Sufferings of the Higher Rebirths

Overview and Detail

# The General Sufferings of Samsara

## Day 14

### Overview

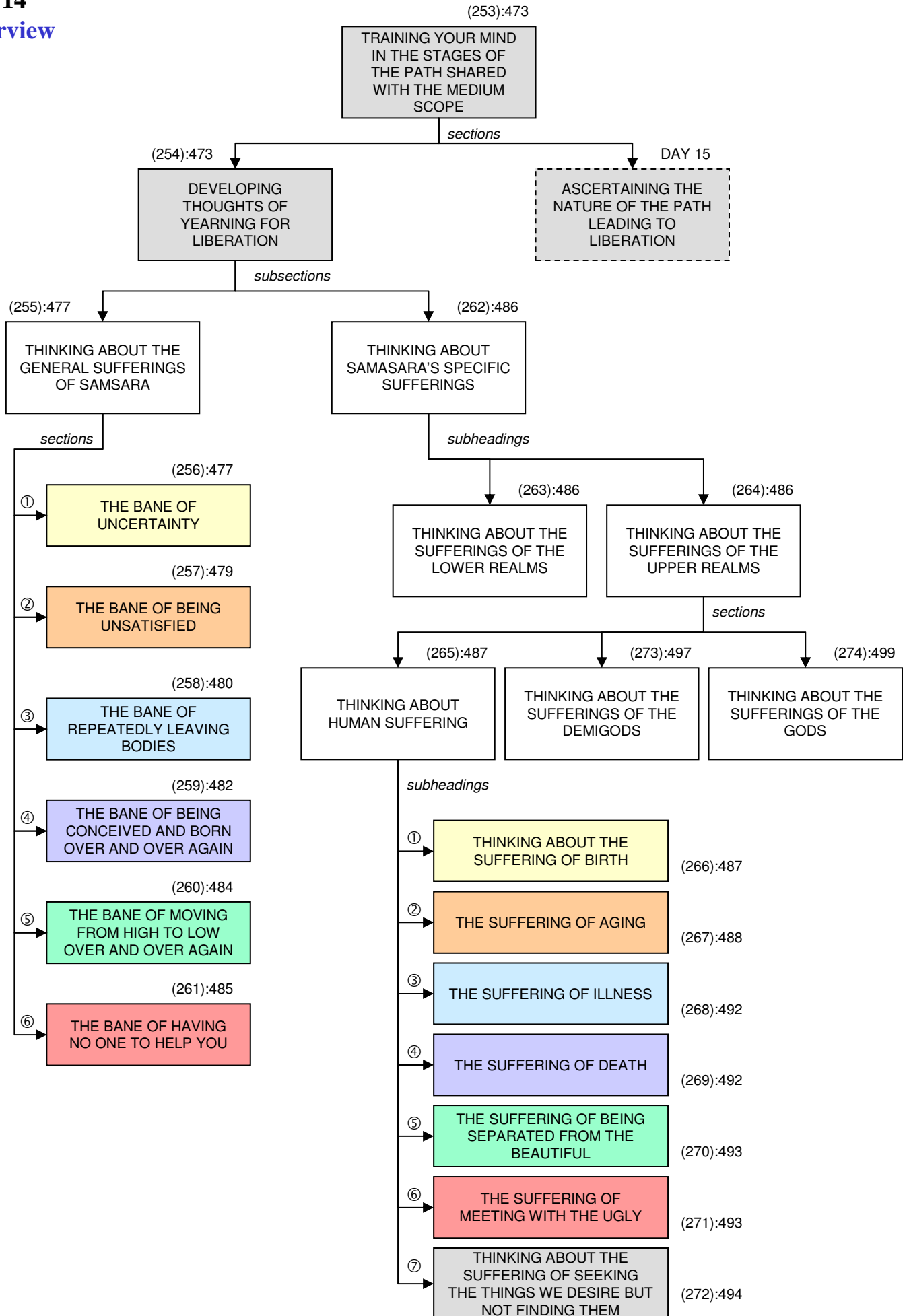

# The General Sufferings of Samsara

## Day 14

### Details

Page 474

(254):473

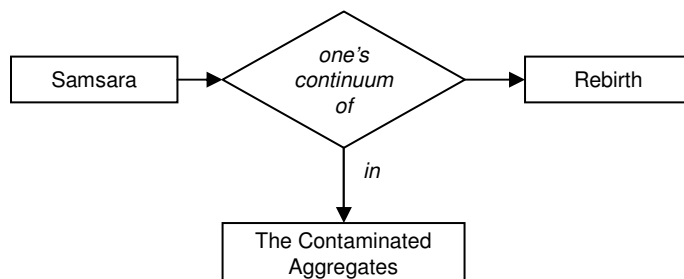
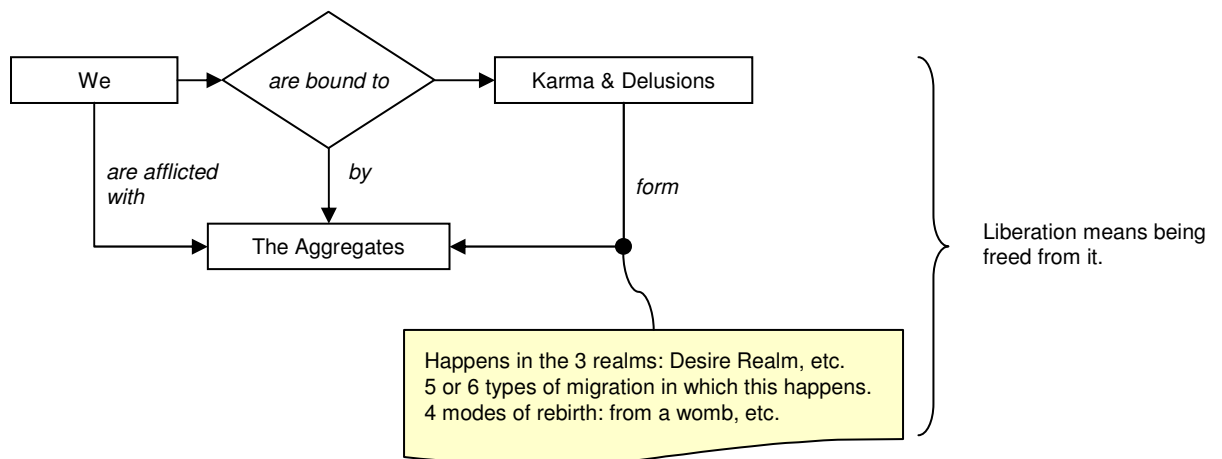
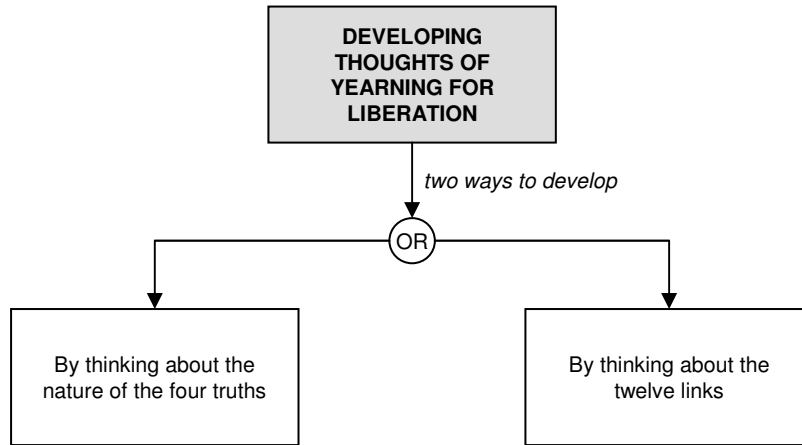

# The General Sufferings of Samsara

## Day 14

### Details

Page 476

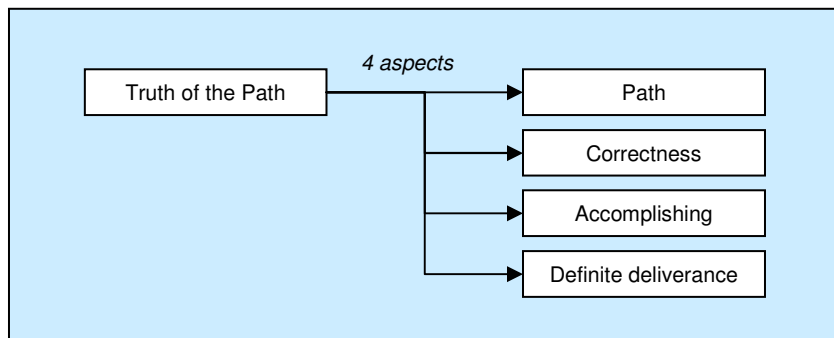
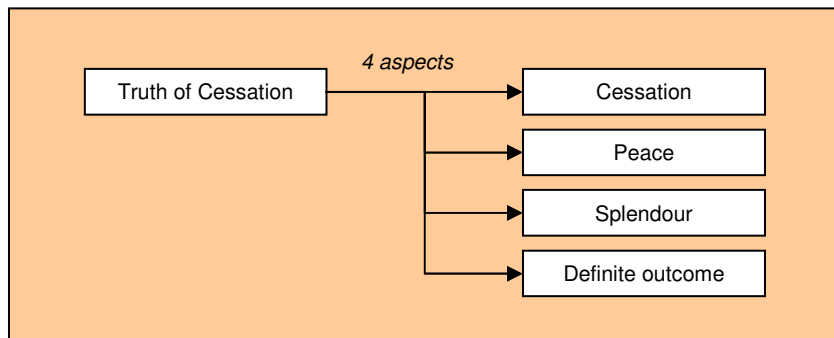
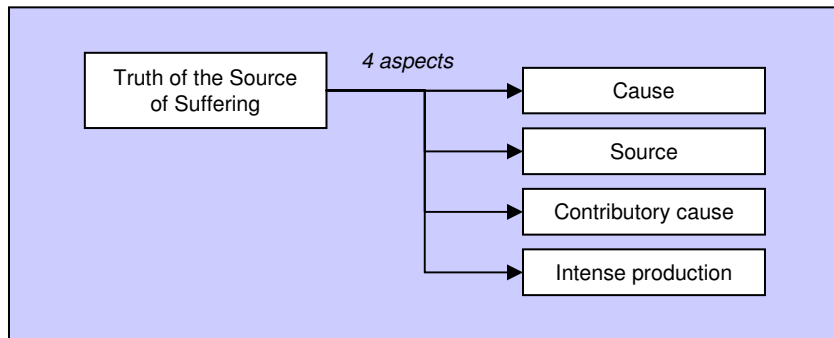
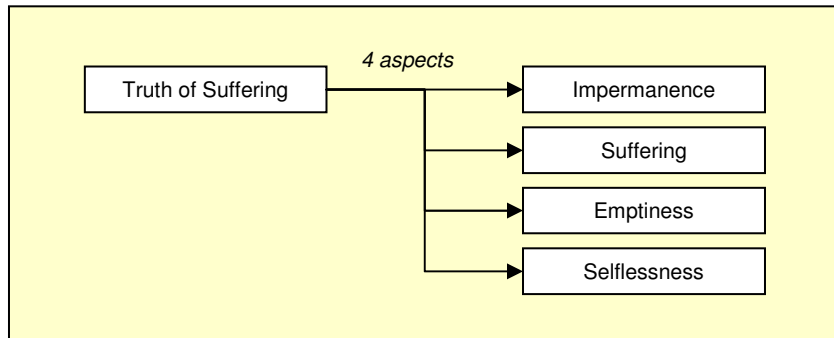

# The General Sufferings of Samsara

## Day 14

### Details

Page 476

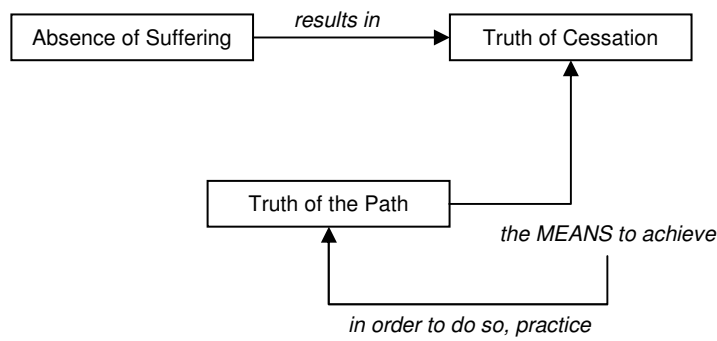
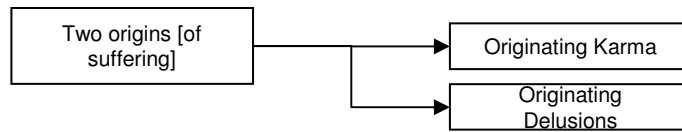
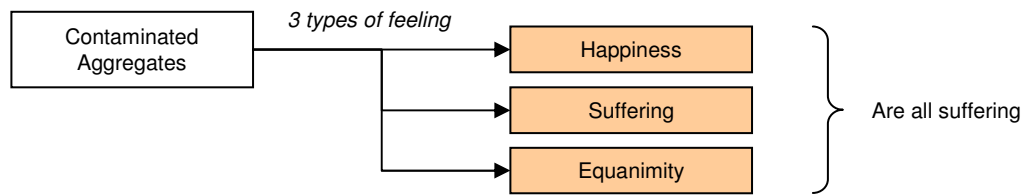

# The General Sufferings of Samsara

## Day 14

### Details

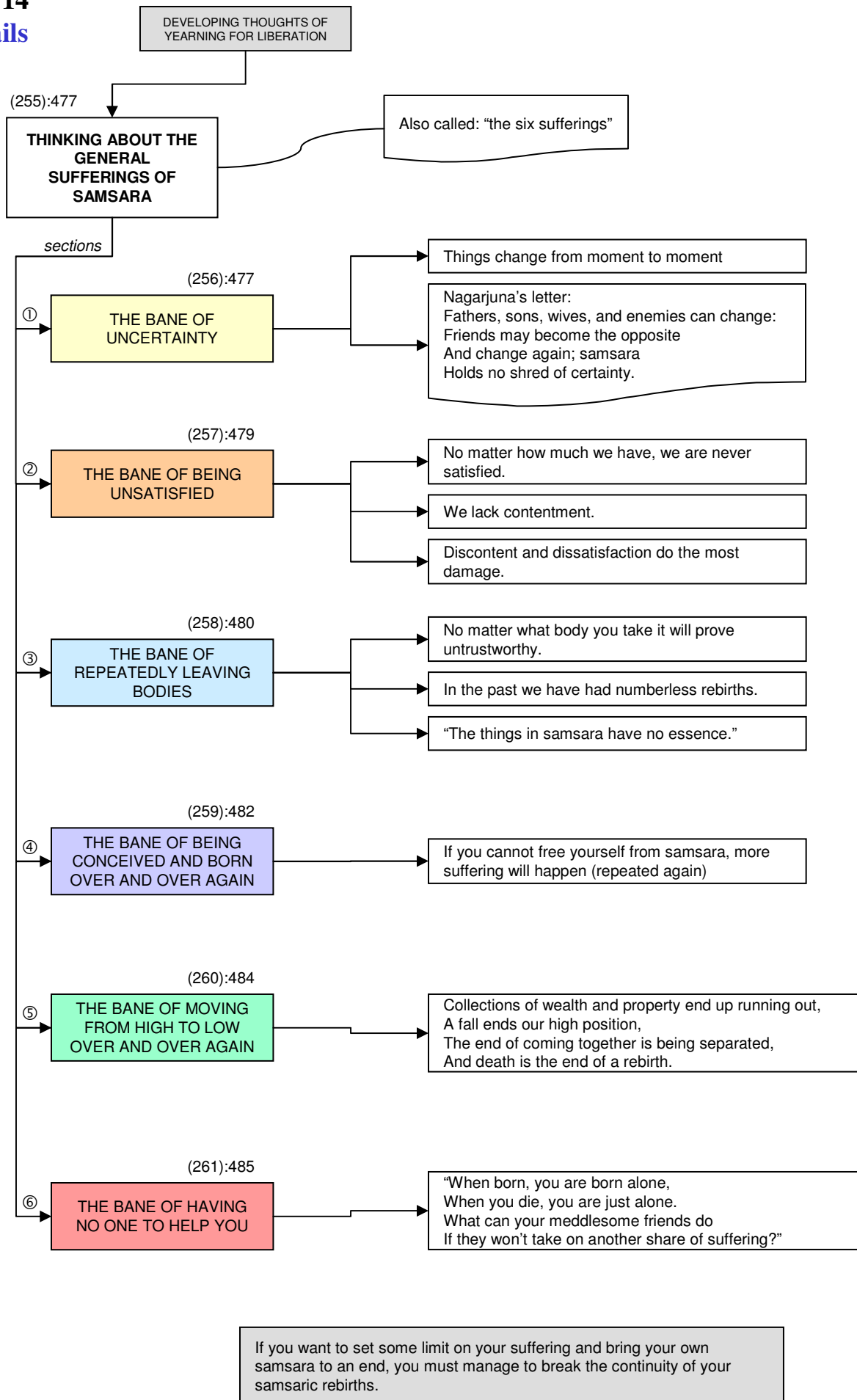

# The Sufferings of the Higher Rebirths

Day 14

Details

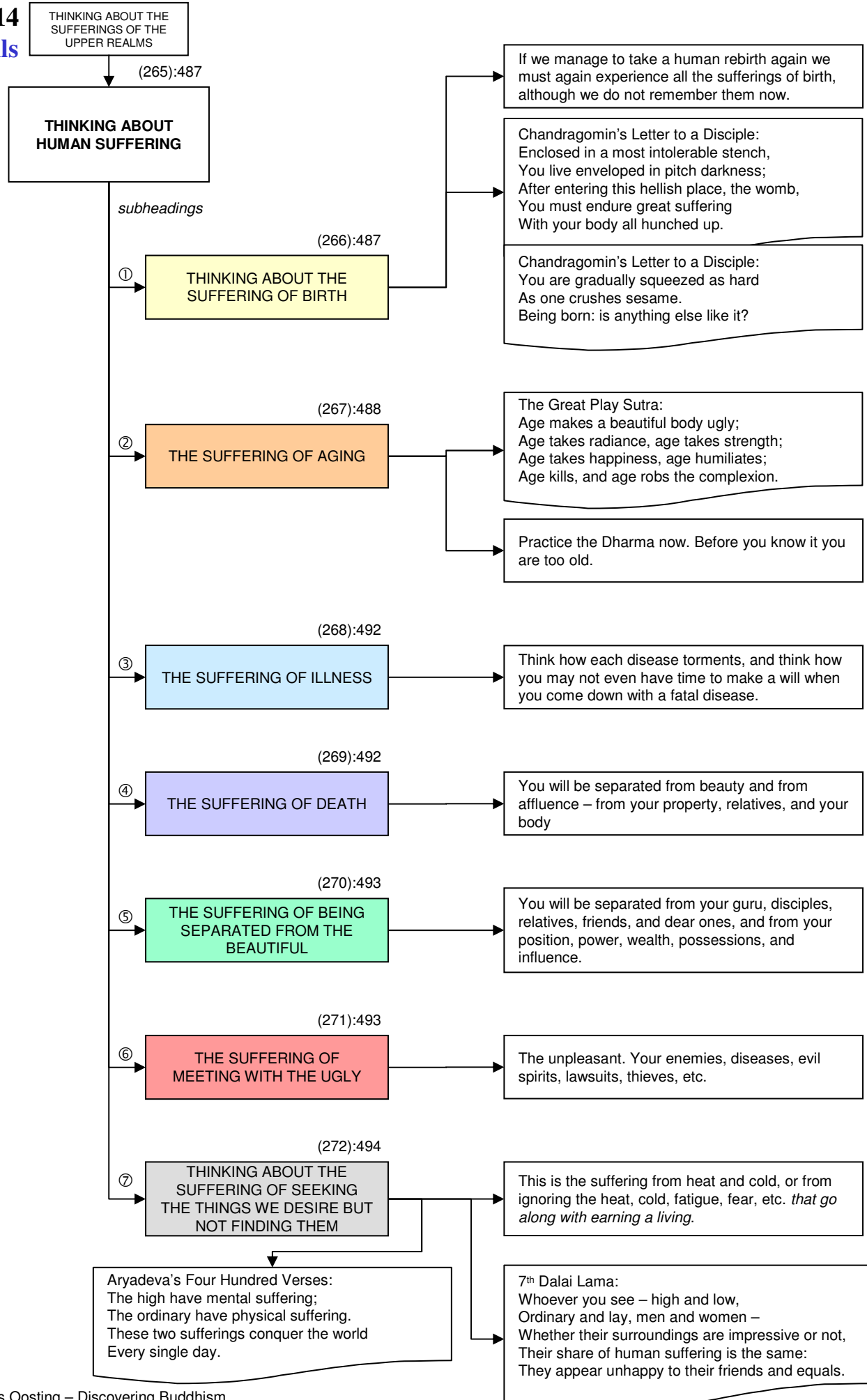

# The Sufferings of the Higher Rebirths

## Day 14

### Details

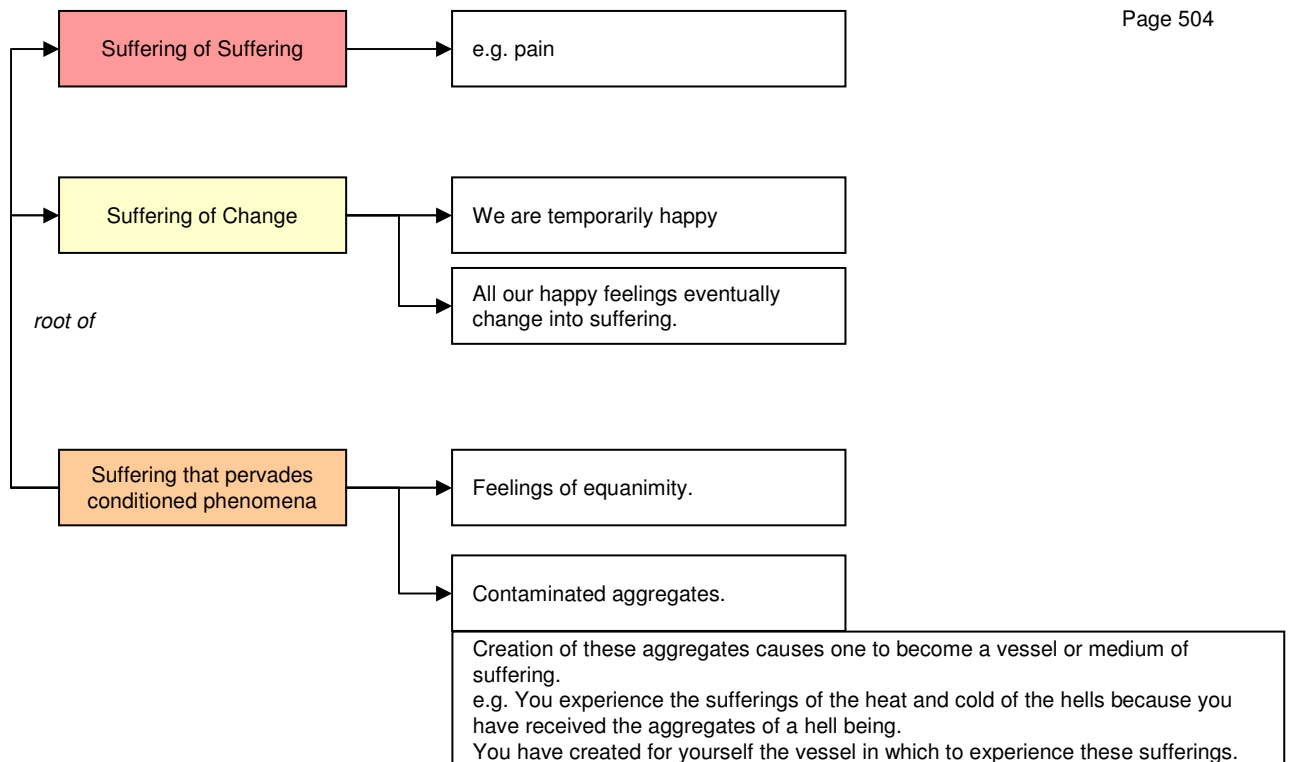
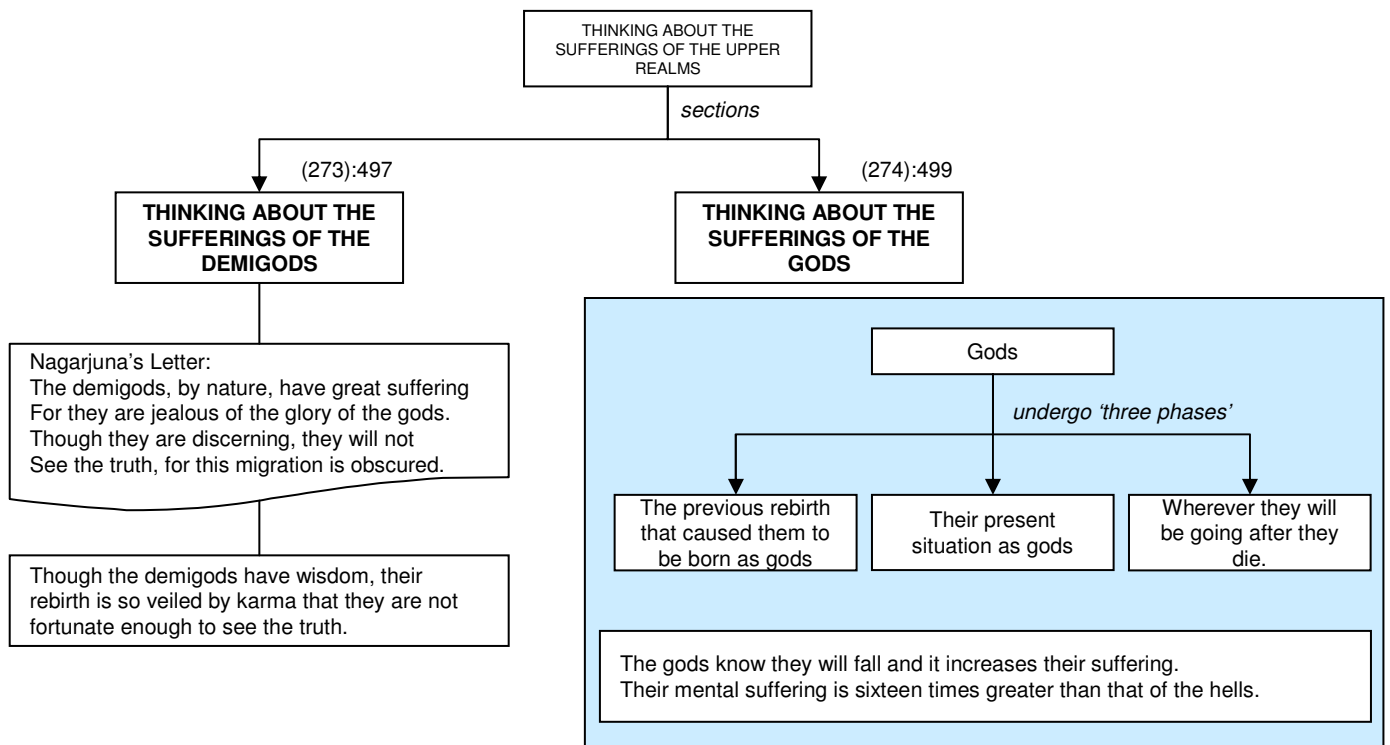

# The Sufferings of the Higher Rebirths

## Day 14

### Details

Page 504/505 contains an interesting paragraph.

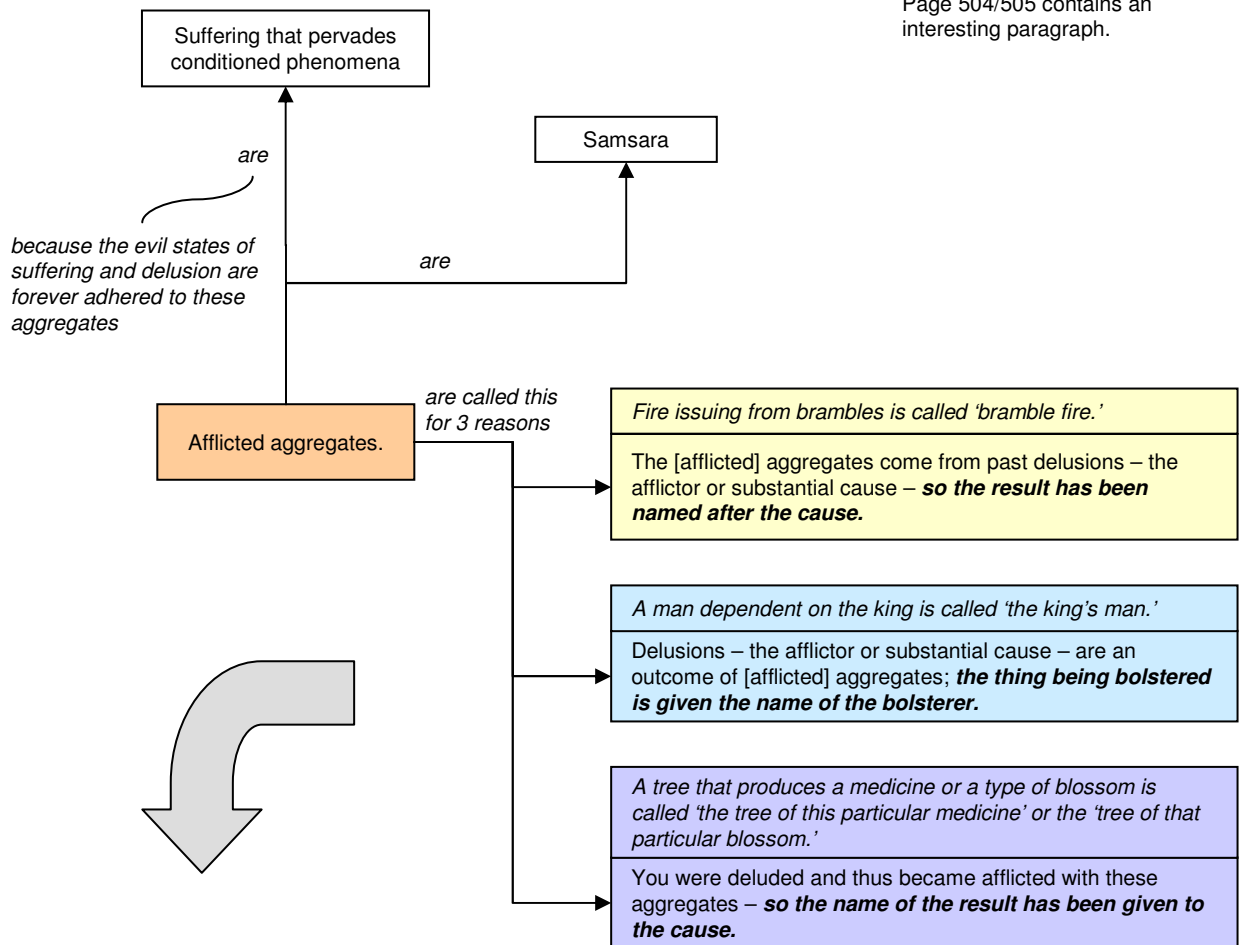

In a diagram it looks as follows:

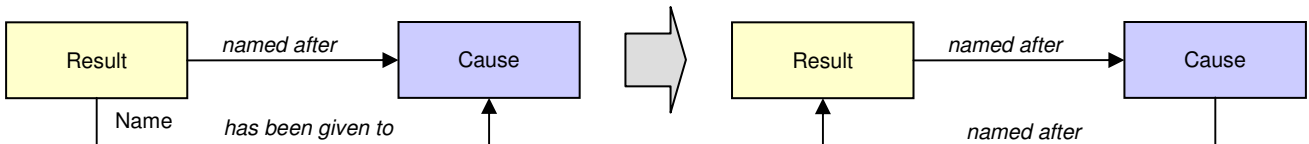
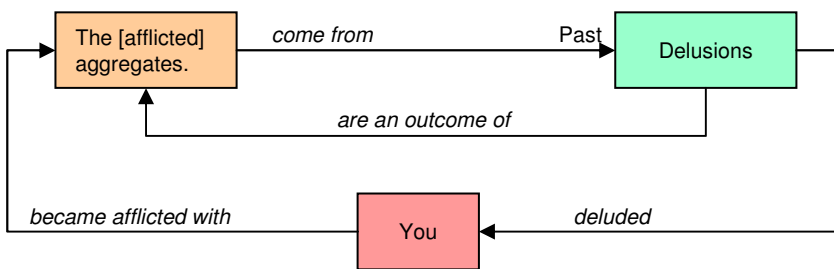

As long as one has these aggregates, each time one does not have the feeling of suffering one will immediately afterwards be made to develop much suffering by various means.

The aggregates created the vessel for the suffering of this rebirth because they create the future rebirth that leads to suffering.

Among all sufferings, the aggregates are the worst: 'samsara' is a state of helplessness in which one receives the burden of contaminated, afflicted aggregates by virtue of karma and delusion.

**DAY 15**

**Understanding the Causes of Samsara**

**Overview and Detail**

# Understanding the Causes of Samsara

## Day 15

### Overview

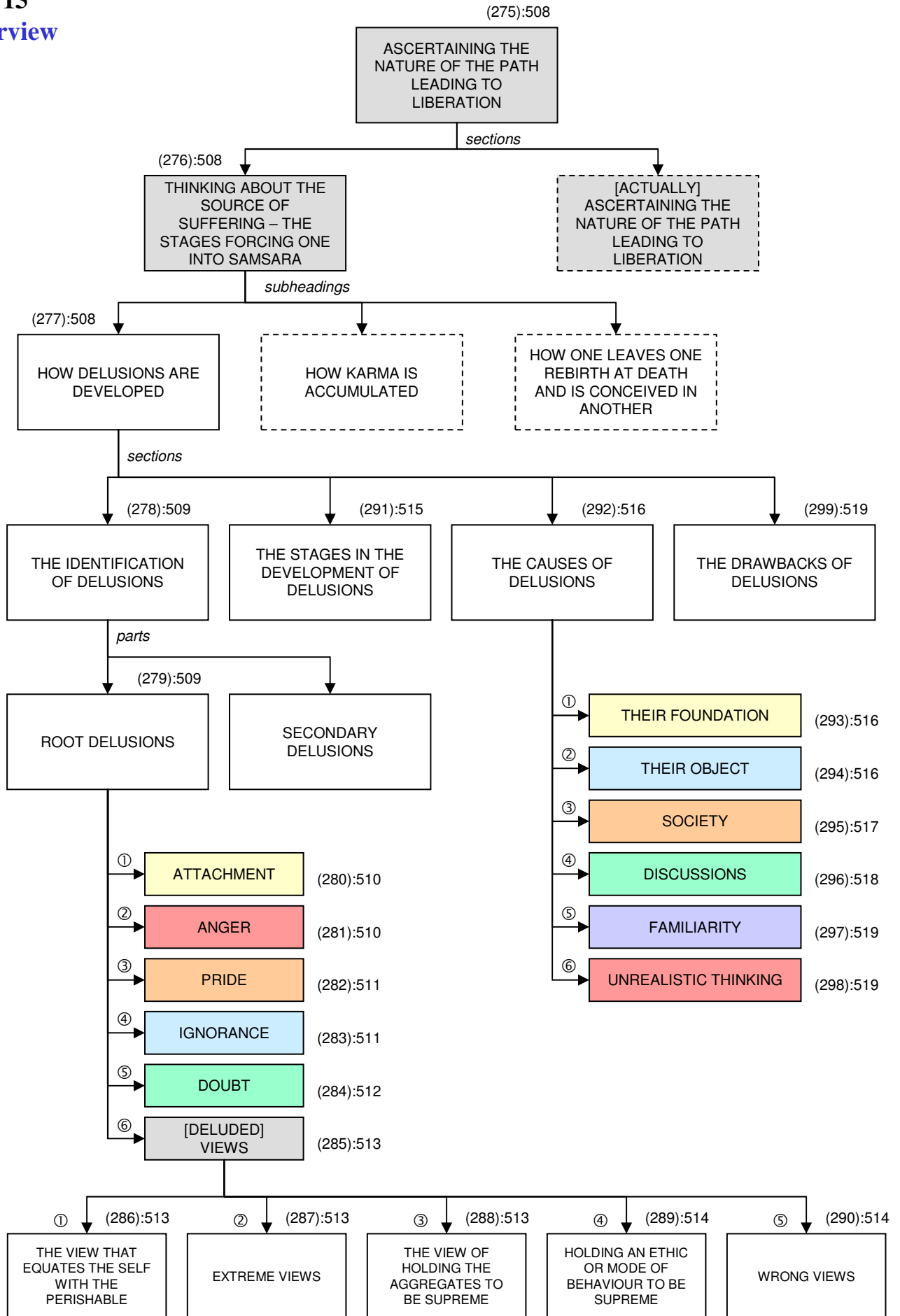

# Understanding the Causes of Samsara

## Day 15

### Overview

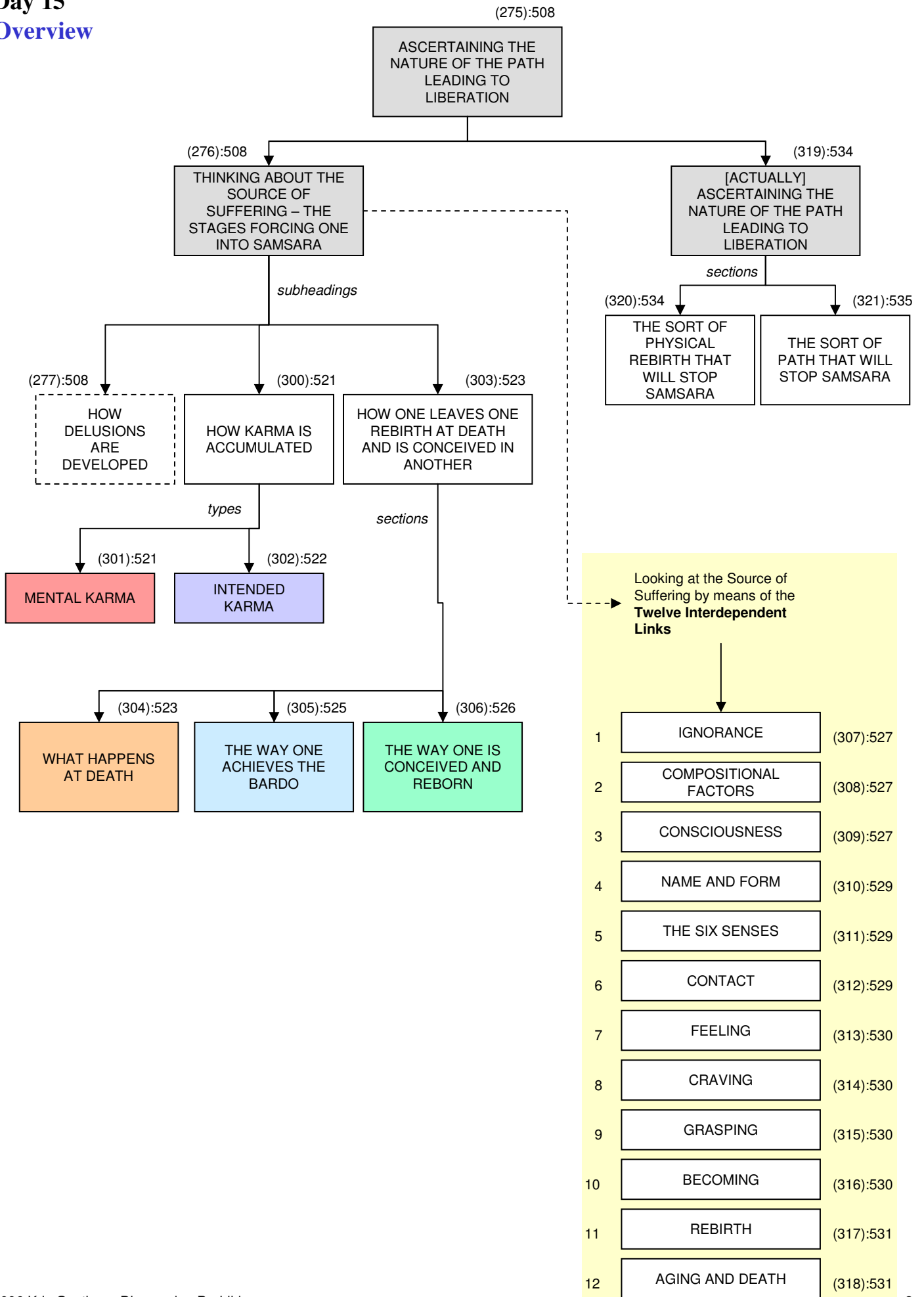

# Understanding the Causes of Samsara

## Day 15

### Overview

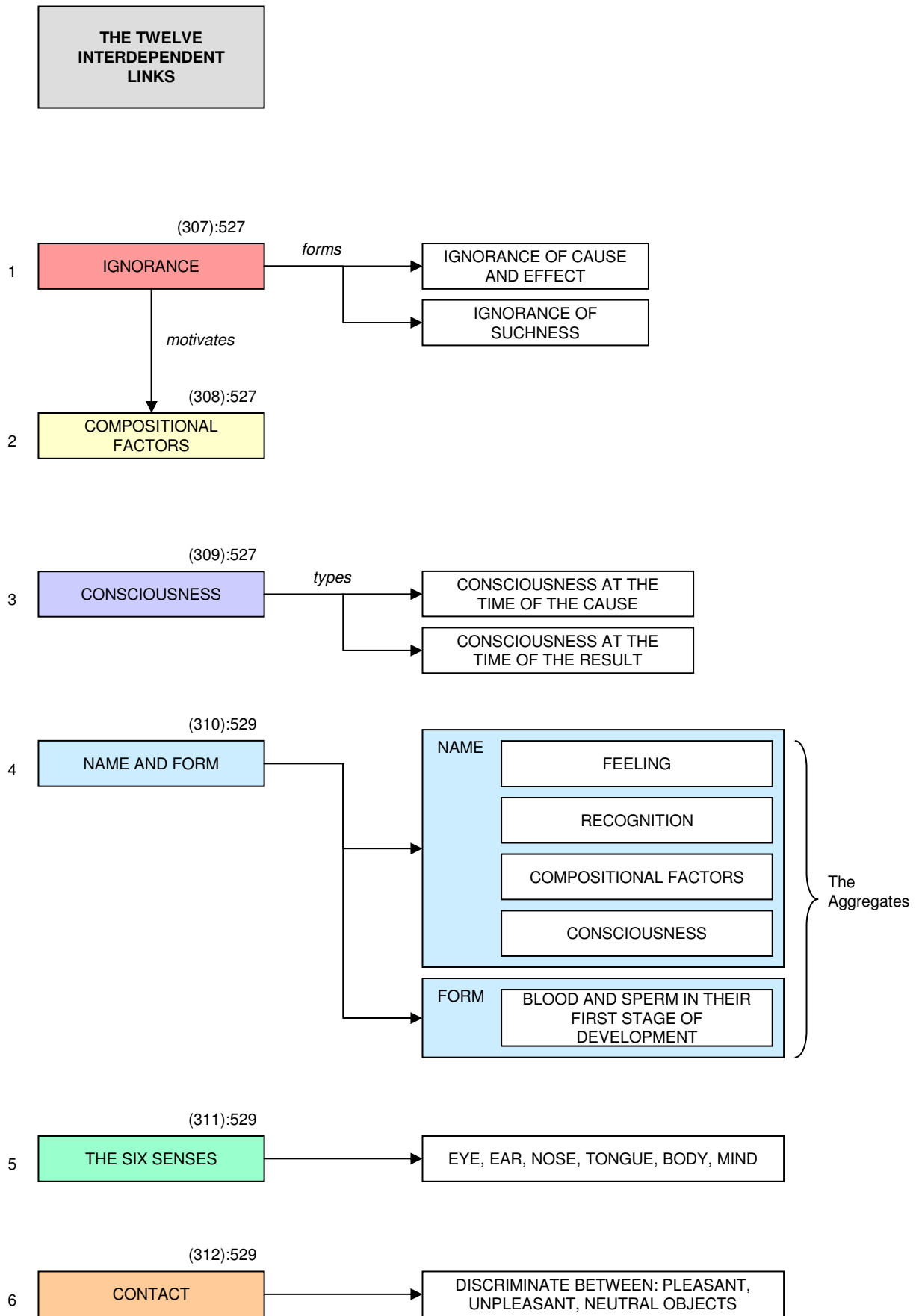

# Understanding the Causes of Samsara

## Day 15

### Overview

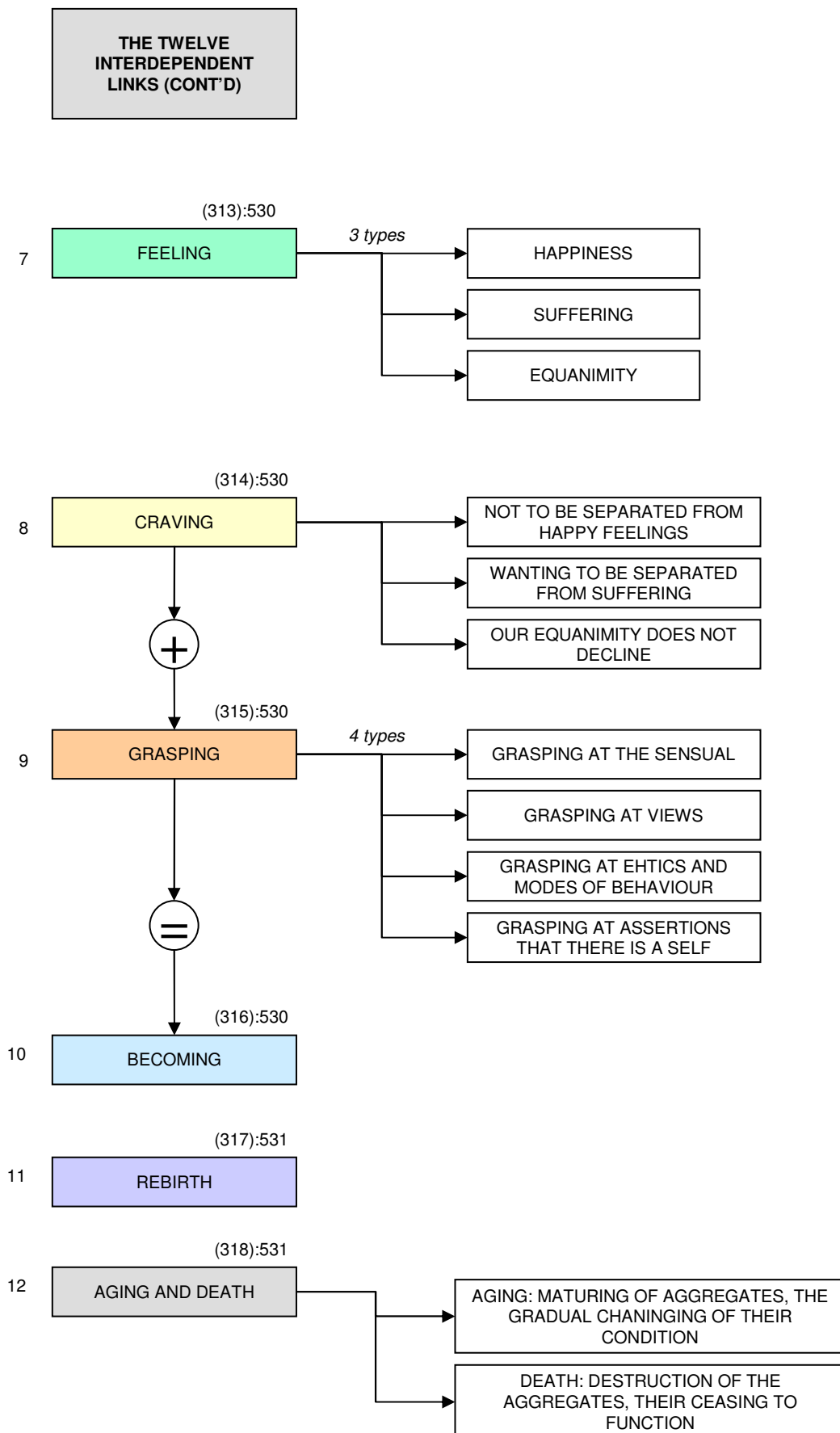

# Understanding the Causes of Samsara

## Day 15

### Details

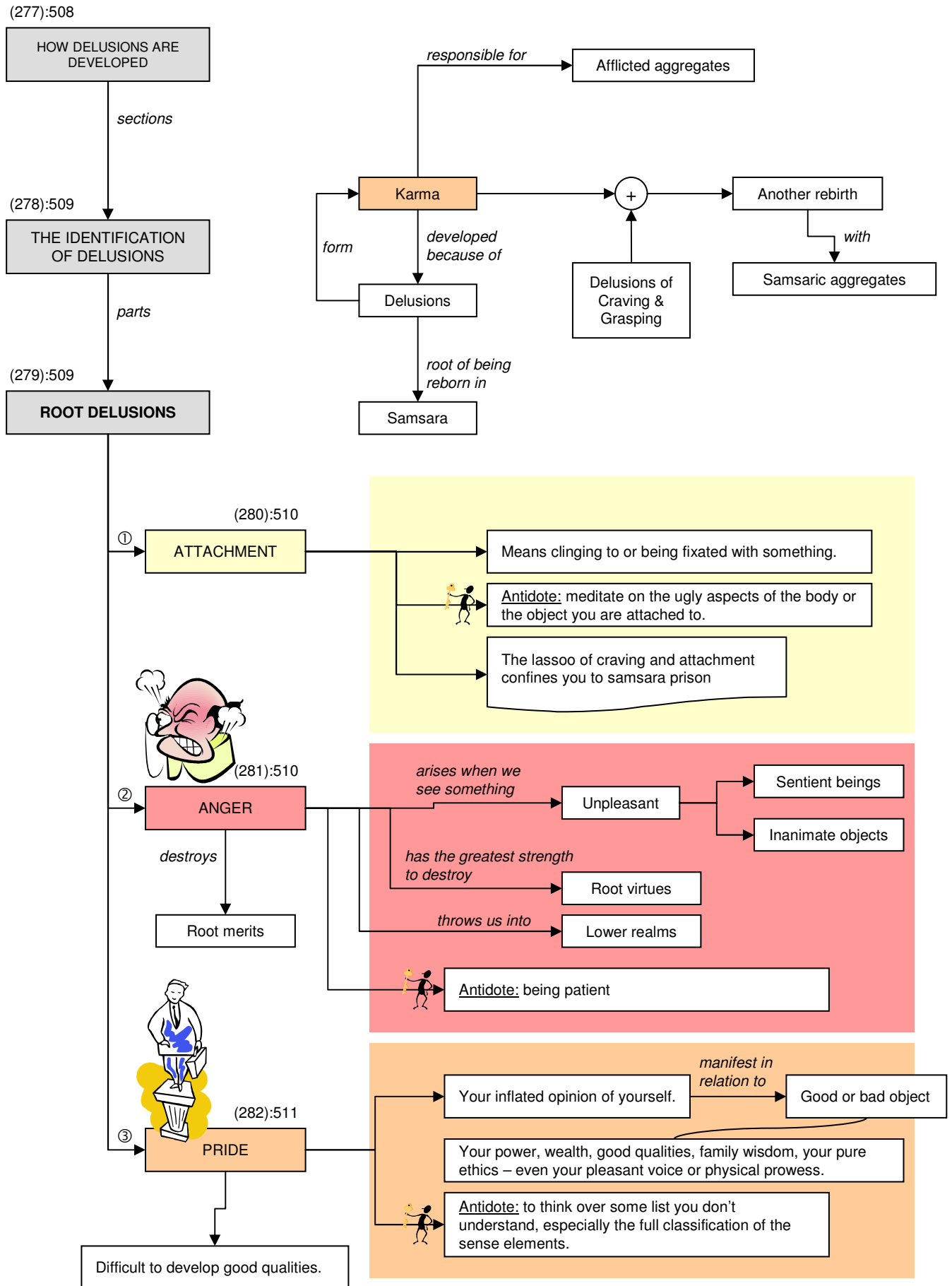

# Understanding the Causes of Samsara

## Day 15

### Details

(277):508

HOW DELUSIONS ARE DEVELOPED

*sections*

(278):509

THE IDENTIFICATION OF DELUSIONS

*parts*

(279):509

ROOT DELUSIONS

④

(283):511

IGNORANCE

*root of all*

Delusions

Tibetan: ma rig pa

Rig pa: 'to know'

Ma: negative particle

Not knowing, not seeing, not understanding, being unclear.

Like blindness – not seeing the nature or mode of existence of something.

Four truths, cause and effect, Three Jewels, etc.

⑤



(284):512

DOUBT

*directed towards*

Four truths, cause and effect, Three Jewels, etc.

*in*

Four truths

*preventing from*

Developing realizations

*in*

Law of cause & effect

*prevents*

Attaining high rebirth

# Understanding the Causes of Samsara

## Day 15

### Details

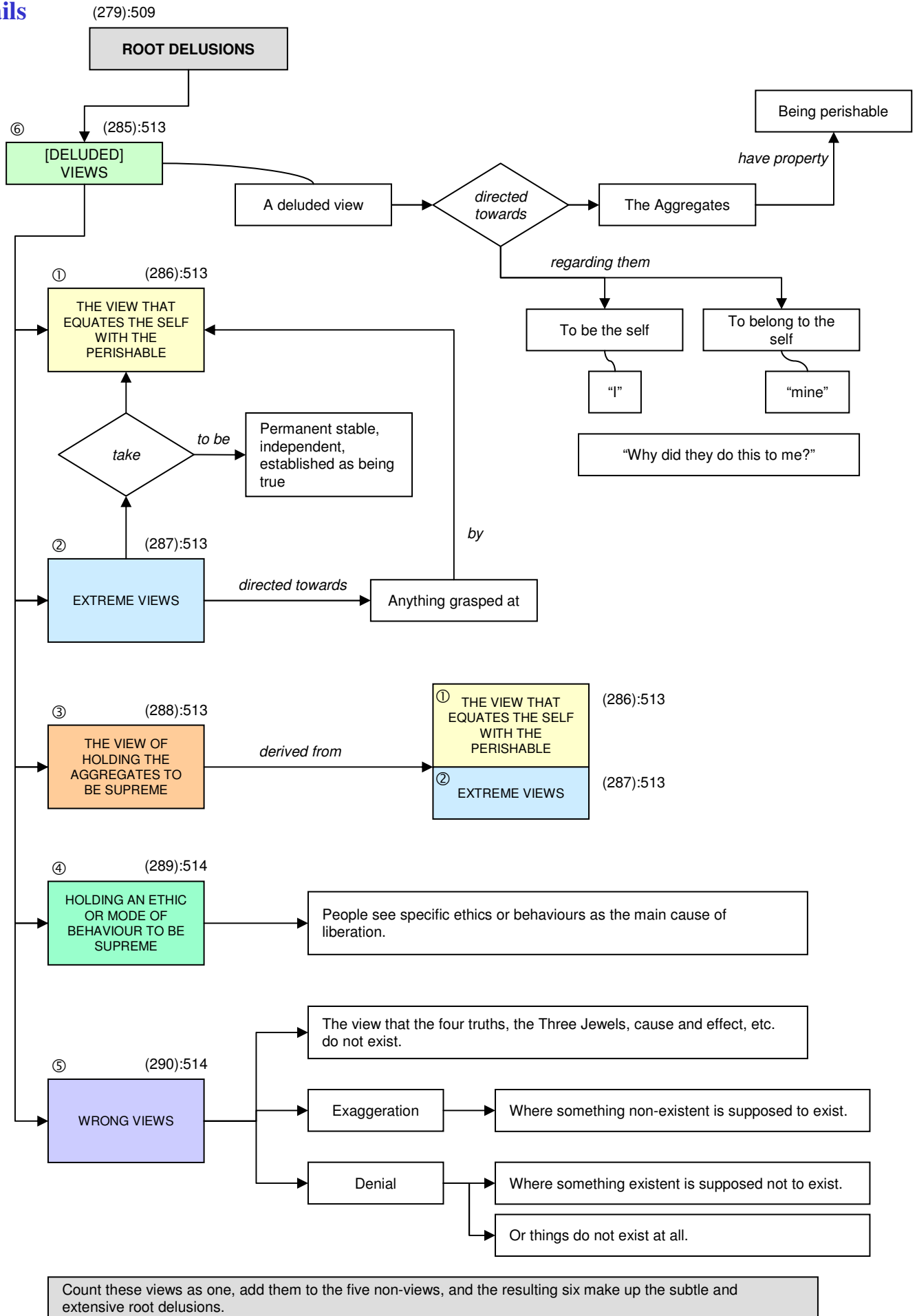

# Understanding the Causes of Samsara

## Day 15

### Details

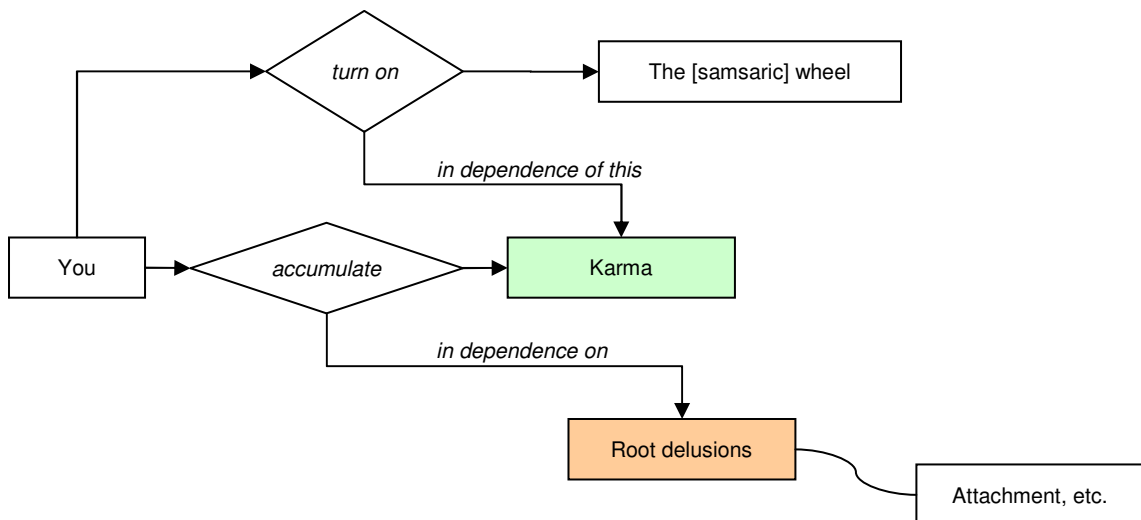
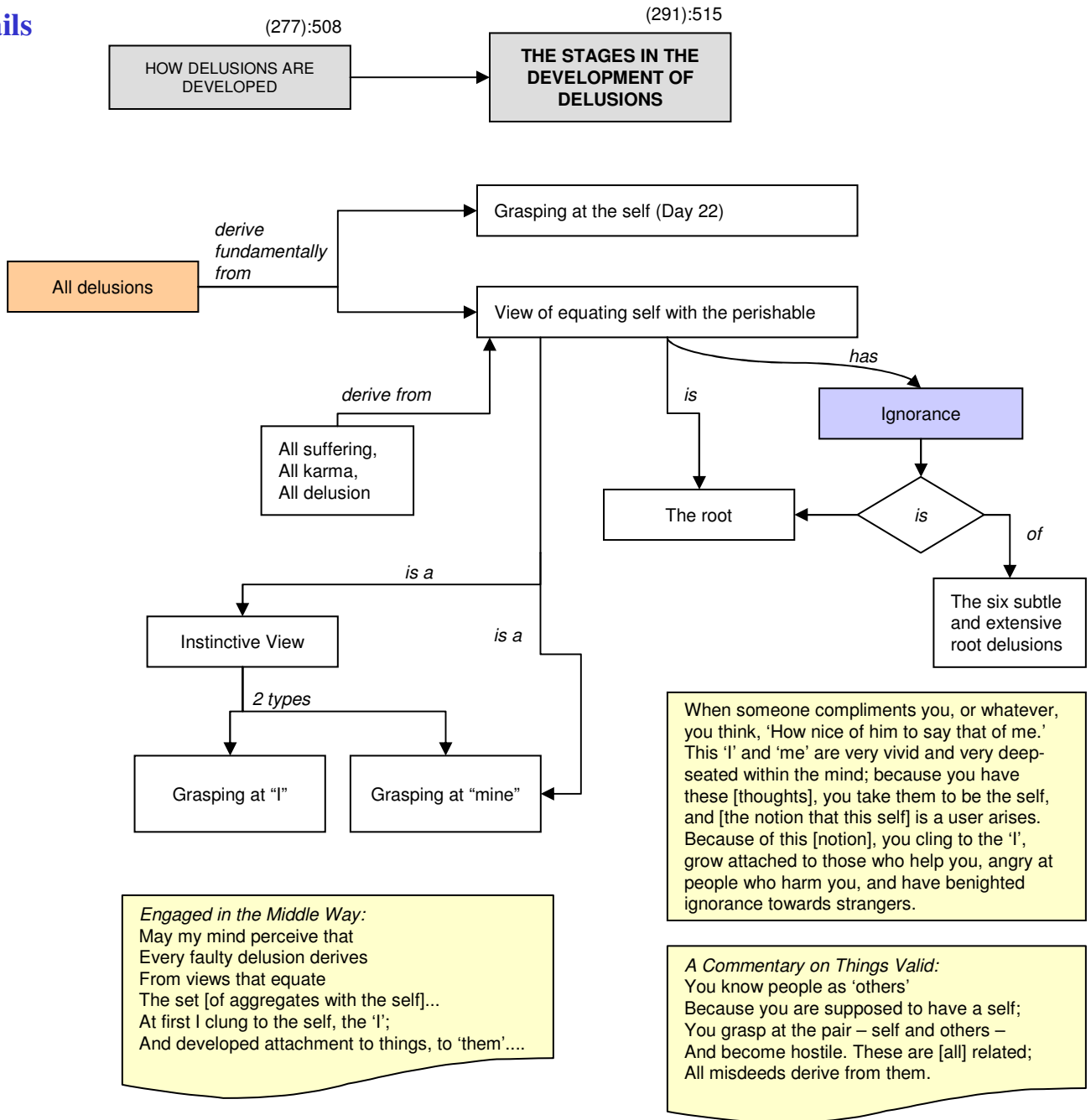

# Understanding the Causes of Samsara

## Day 15

### Details



Page 516

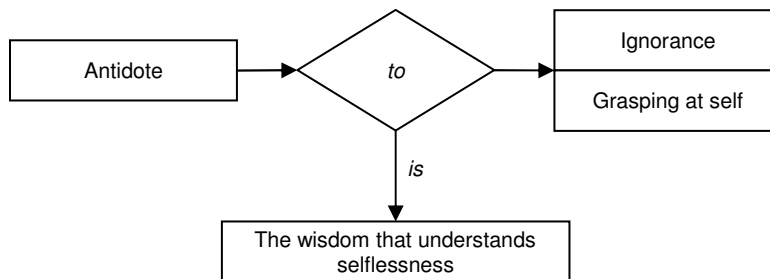
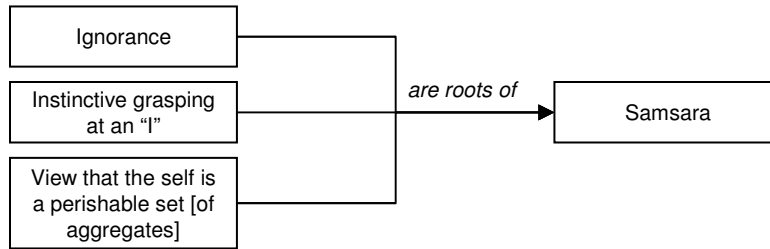

*The Sutra on the Ten Stages:*  
In this world, all misdeeds ever committed came from manifest clinging to a self. Without manifest clinging to a self, these would not happen.

# Understanding the Causes of Samsara

## Day 15

### Details

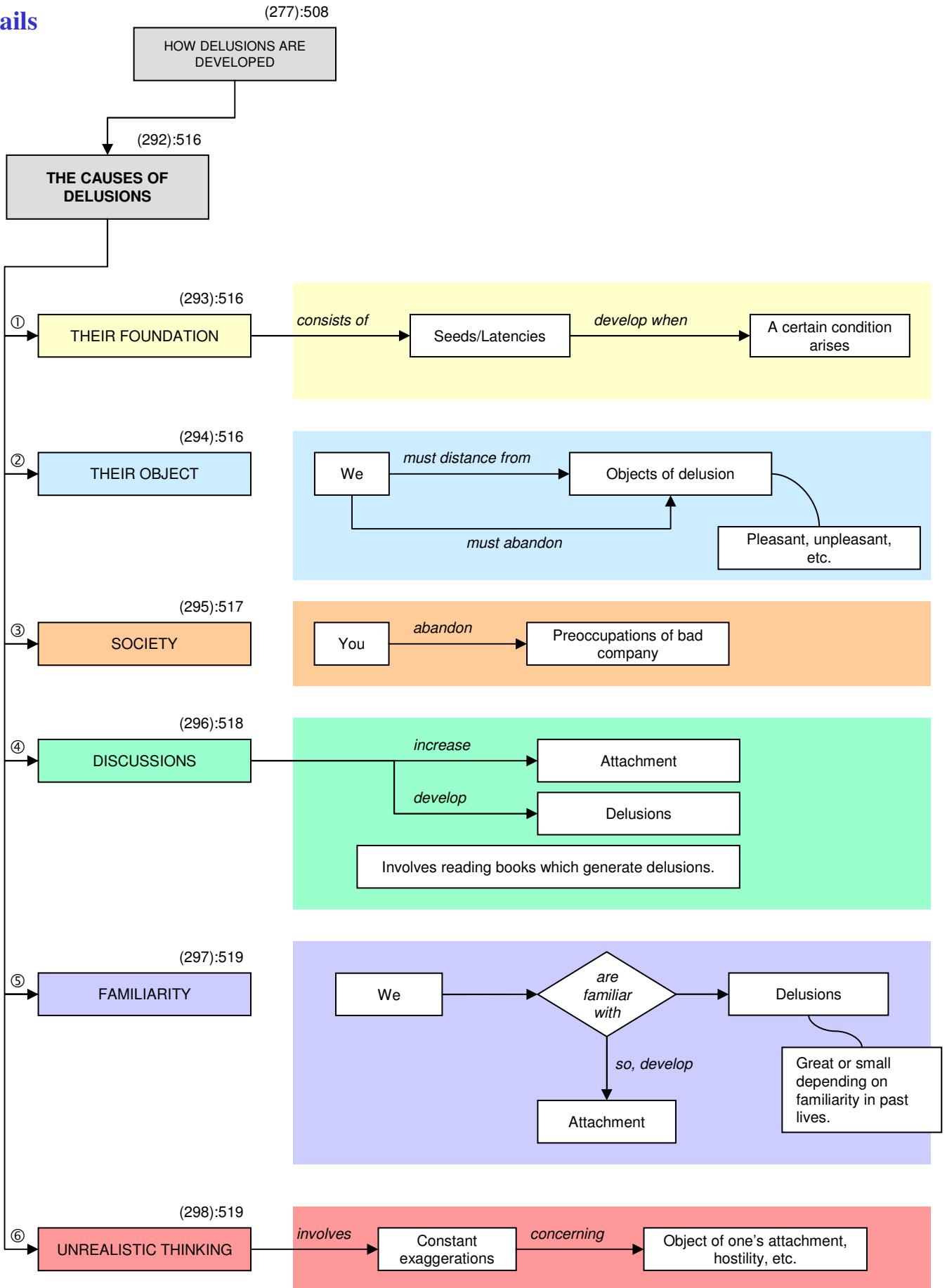

# Understanding the Causes of Samsara

## Day 15

### Details

(299):519

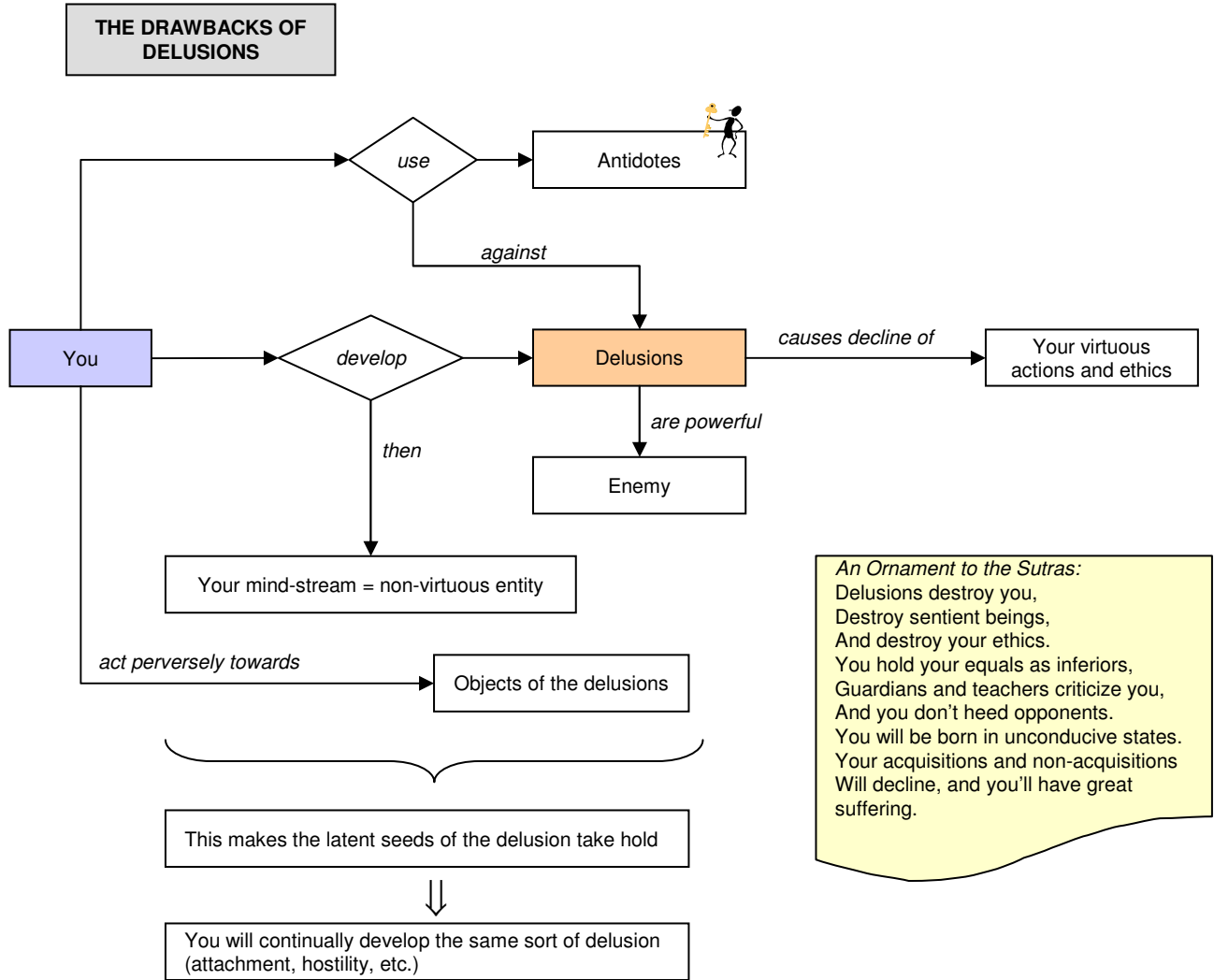

(300):521

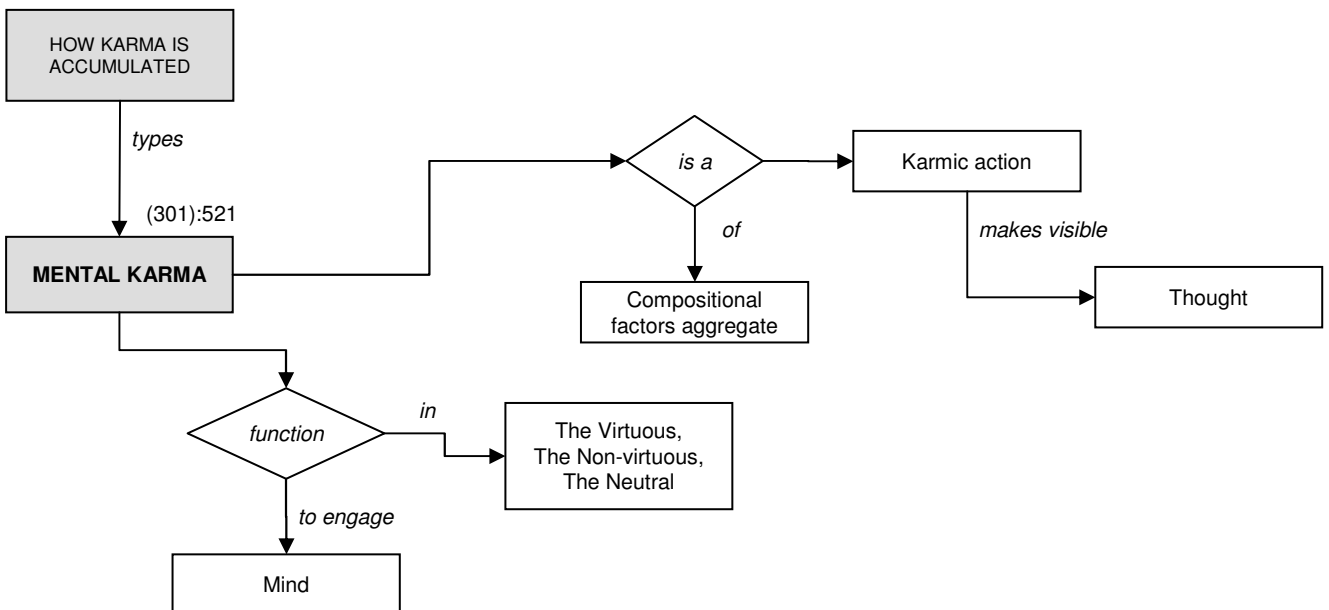

# Understanding the Causes of Samsara

## Day 15

### Details

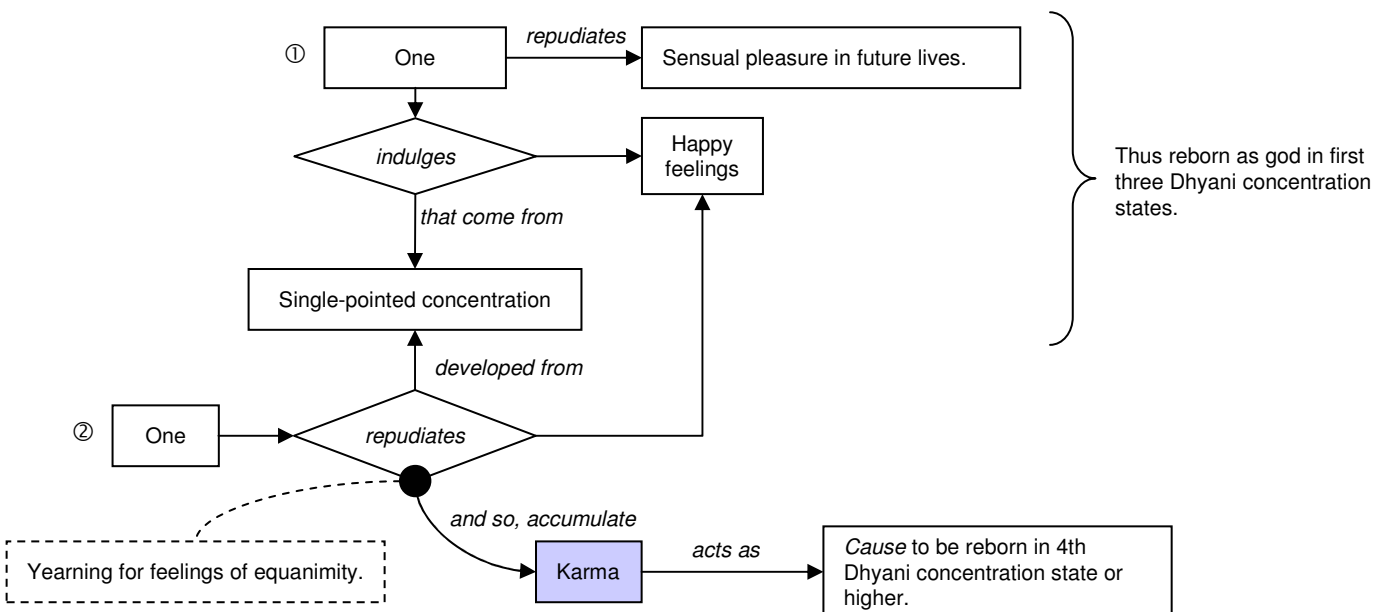
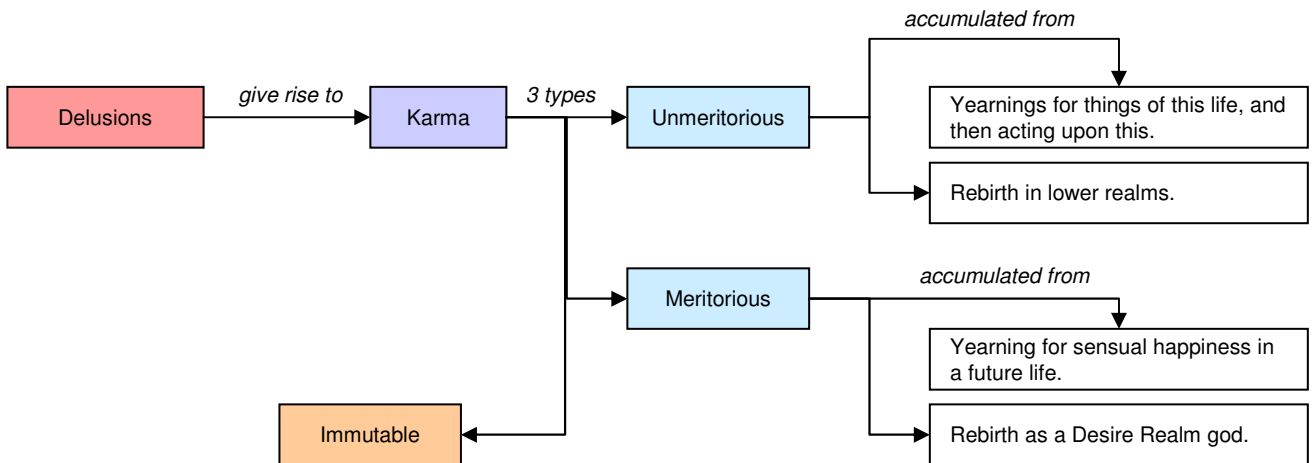
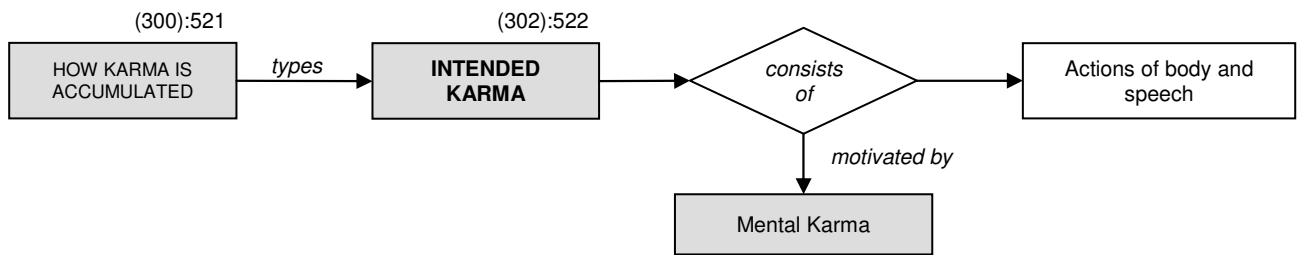
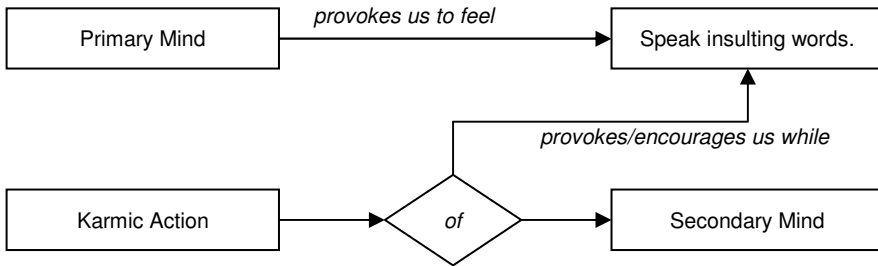

# Understanding the Causes of Samsara

## Day 15

### Details

Page 522

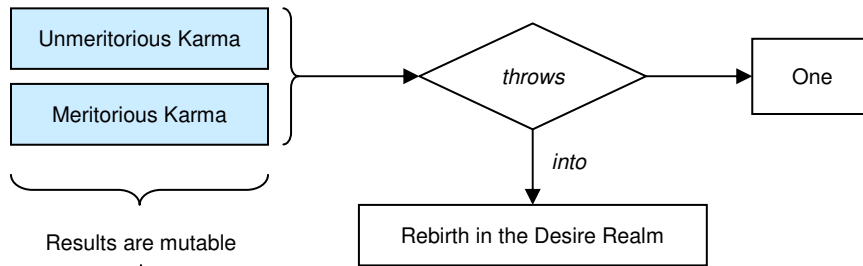

Results are mutable

#### Example:

One may already achieved the bardo state of a being on its way to the hells, but through the power of one's guru, of rituals, of the secret tantras, and so on, one's bardo state can be changed so that one is able to receive rebirth in the upper realms.

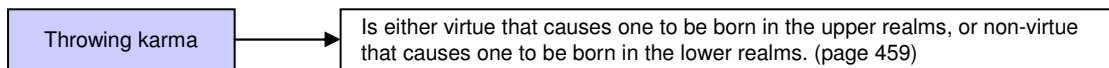

#### Treasury of Metaphysics:

Virtuous karma is merit to be born into the Desire Realm. Karma to be born higher is immutable; This karma is immutable because It will ripen only in these higher levels.

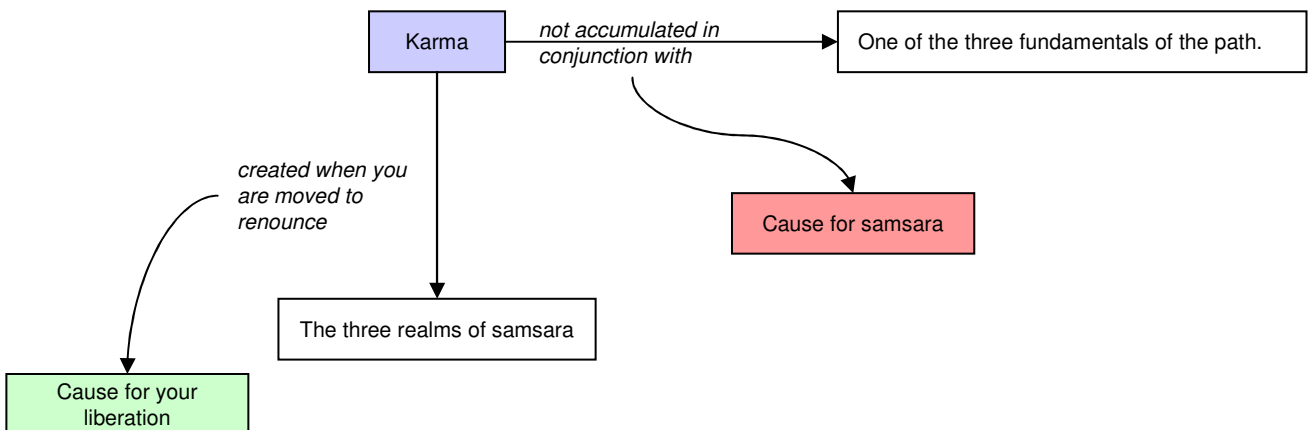

# Understanding the Causes of Samsara

## Day 15

### Details

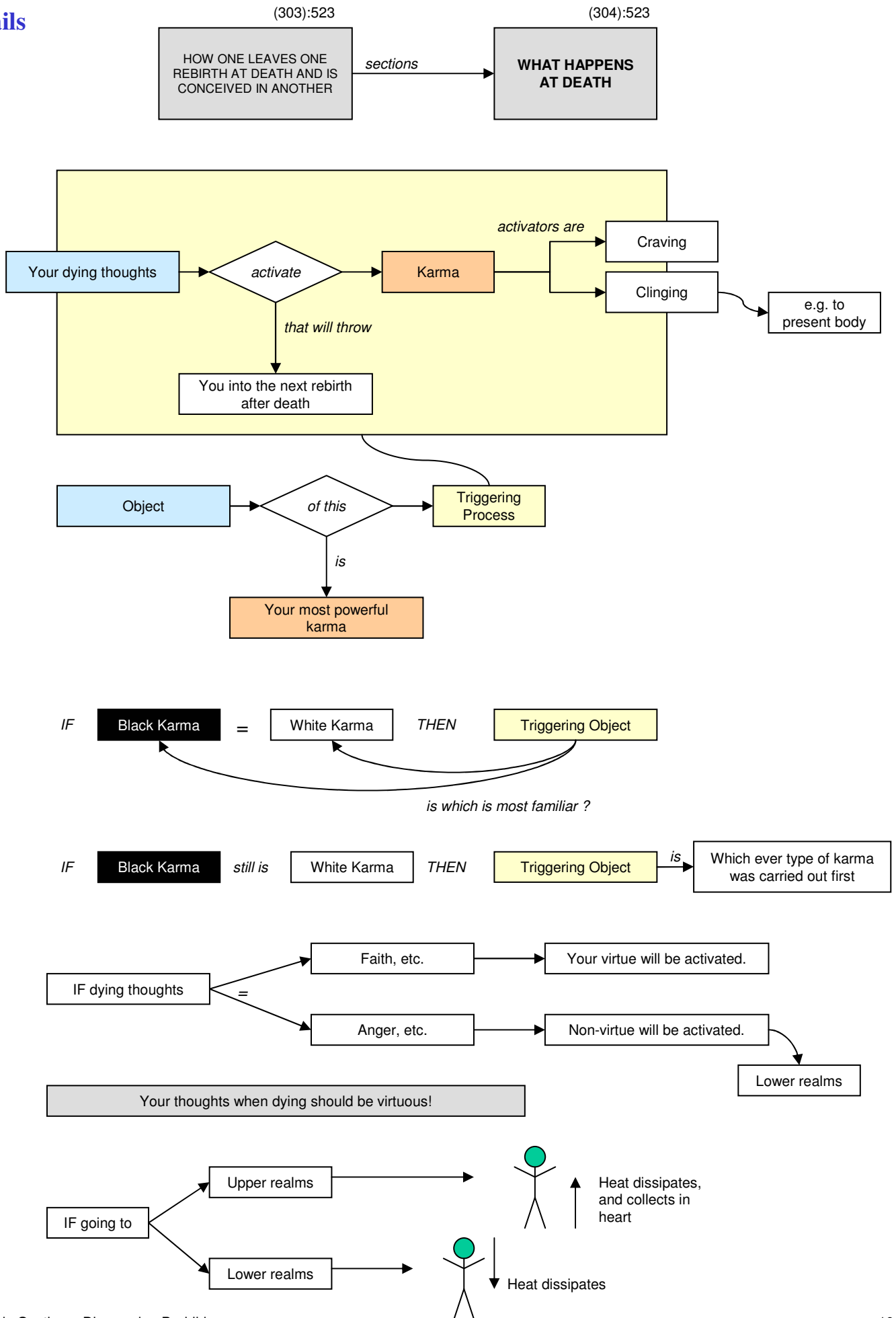

# Understanding the Causes of Samsara

## Day 15

### Details

